

As Europe's largest provider of boiler equipment, GESTAMP meets all the needs of today's market: a broad spectrum of products, faster time-to-market for new products, more performance for less money and customized solutions and services. This unique market position is based on extensive experience acquired over more than 30 years in the design and manufacture of high-quality safety-oriented control equipment. To compete in a truly global market, GESTAMP is continuing to consolidate the domestic market and, simultaneously, stepping up its efforts to deepen international activities outside Europe in order to optimize and extend its network of sales and marketing organizations all over the world.

Industrial Electronics



	Page
Level Control, Monitoring and Limitation	77
How to read type codes	78 – 79
Boiler equipment in acc. with TRD 604 / EN 12952/.53	80 – 81
Principles of measurement and fields of application	82
Equipment for steam and hot-water boiler plants	83
Type Approvals at a Glance	84 – 86
Spector BUS	
Basic principles	87
Level limitation (low/high-level alarm).....	88 – 89
Level control	90 – 91
Spector Compact	
Level control/limitation	92 – 93
Pump control	92 – 93
Conventional Design	
Self-monitoring low/high-level alarms	94 – 95
Modulating level control	96 – 97
Accessories for Liquid-Level Alarms Fitted in External Level Pots	
Level electrodes and controls.....	98 – 99
Level Probes and Control Units for Very High Pressure Ranges (NRG 211)	100 – 101
Marine Applications	102 – 103

GESTRA Spector Bus



This future oriented concept offers you the following advantages

1. No overheating:

- ▶ Patented thermal barrier in cylindrical body above electrode flange
- ▶ Terminal box equipped with electronic temperature fuse
- ▶ Patented connection arrangement
- ▶ Practically unaffected by thermal conditions

2. Easy installation and fast commissioning:

- ▶ Control unit features freely accessible terminals
- ▶ Large terminal box makes for easy installation

3. Reduced costs:

- ▶ Simplified stockkeeping and reduced spare parts inventory
- ▶ Only a single cable is required between boiler and control cabinet
- ▶ Reduced installation and material costs
- ▶ Simplified wiring scheme reduces labour costs
- ▶ Only one PG thread
- ▶ Only five input terminals
- ▶ Only one cable in control cabinet for all sensing units
- ▶ Fewer control units thanks to increased functionality. Example: TRD 604: only 4 instead of 7 items of equipment

- ▶ Optimum system adaptation without any additional wiring effort

4. Increased safety, reliability and availability of plant:

- ▶ Active cable monitoring
- ▶ Cable can now be more than twice as long
- ▶ Easy to integrate in visual display and intelligent automation systems
- ▶ Remote diagnosis and parameterisation
- ▶ Interconnection of further systems thanks to CANopen protocol

All-purpose control terminal and display unit URB:

One single operating unit for all systems.

With the URB all standard functions of CAN bus systems can be easily called up and adjusted. The switchpoints can be established independently of the actual water level by means of the keypad. When using this controller as second liquid level indicator acc. to TRD or EN 12952/..53 a water level gauge glass can be dispensed with.

Continuous indication of the actual conductivity value as stipulated by WÜ (Water Level Control) 100.

Principles of Measurement

Conductivity measurement

The water level is detected between the electrode tips and the vessel wall (or reference electrode) and evaluated for control or limitation purposes. In this case it is essential that the medium is electrically conductive. The high-integrity self-monitoring design of the level alarms ensures constant supervision of the insulating seal and electrode entry, immediately recognizing malfunctions in the system and failure of the electrode or supply cables. In addition, the equipment features periodic self-checking of the electronic control unit and the corresponding output contacts. Self-monitoring equipment with periodic self-checking is required for boilers with temperature/pressure ratings > 1 bar and > 120 °C and a volume > 50 l.

Before installation, the length of the conductivity electrode rods must be cut to the required switching levels.

Capacitance measurement

Electrode rod and vessel wall (or reference electrode) form a capacitor; air and the fluid to be controlled act as dielectric. Due to the different dielectric constants of air and boiler water the capacitance value between the electrode and the vessel wall changes concurrently with level changes.

The switchpoints can be continuously adjusted during operation and multiplied by connecting in parallel several electronic control units.

Types of Controls

Water level limiters

(High-level/low-level alarms)

As soon as the water level exceeds or falls below the adjusted switch-points the burner protection circuit is interrupted (low level) or the feed pump is switched off (high level).



On-off level control

The water level is controlled between two fixed or adjustable switchpoints. The signals are directly transmitted to the feed pump or valve.

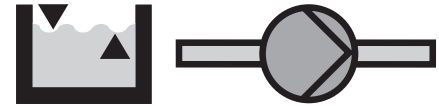

Modulating level control

The water level is continuously monitored and the actual value is compared with the adjusted set point by the associated controller. If a deviation between the two values is detected, a signal will be sent to the control valve to re-adjust the flowrate accordingly, thereby enabling a more economic and efficient steam plant operation.

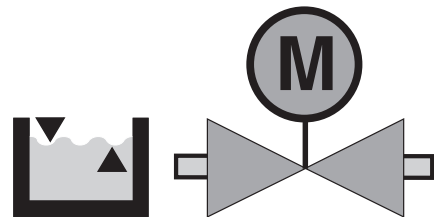

Field Bus System

Digital Data Exchange



The Spector Bus system transfers the digitized measurement data acquired by the level probe to the electronic control unit located in the control cabinet. The centerpiece of this system is the stable and sophisticated CAN bus (Controller Area Network). Several sensors and switches can be interconnected via one bus line.

Apart from active cable monitoring a CAN bus system offers a host of benefits, such as increased design flexibility, reduced installation effort, optimized open and closed loop control, centralized operation and remote monitoring.

The standardised network opens up highly flexible possibilities for configuration. The CANopen protocol is used nowadays in medical equipment, electronic devices for marine applications, public means of transport and in burner and boiler controls of power plants.

Thanks to the many CANbus applications a great number of equipment and interface components are widely available, providing an ideal addition to our product range.

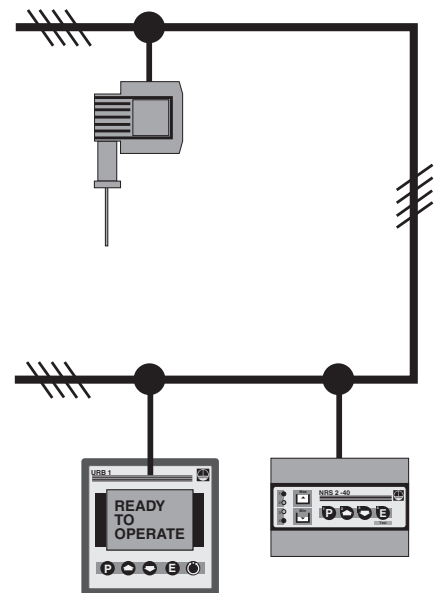

GESTRA Type Designations for Boiler Controls

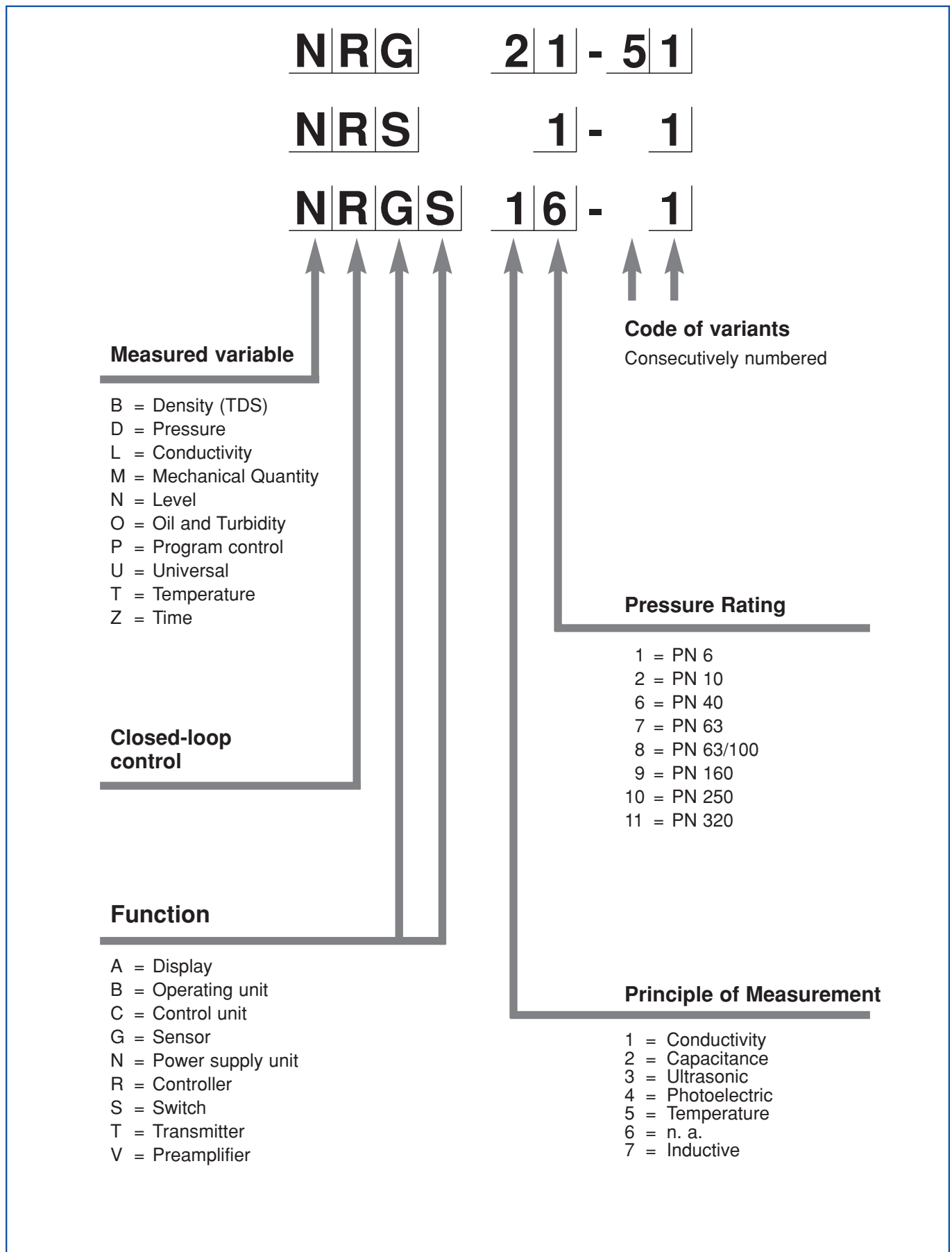

GESTRA Type Designations for Boiler Controls

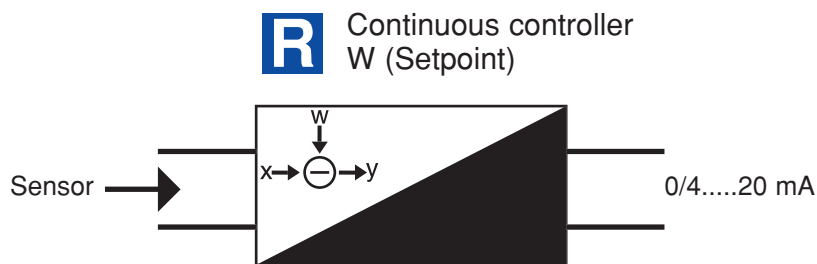
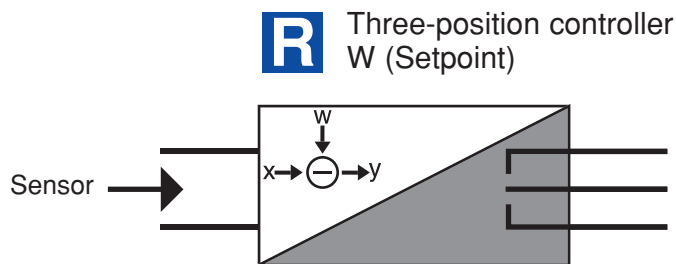
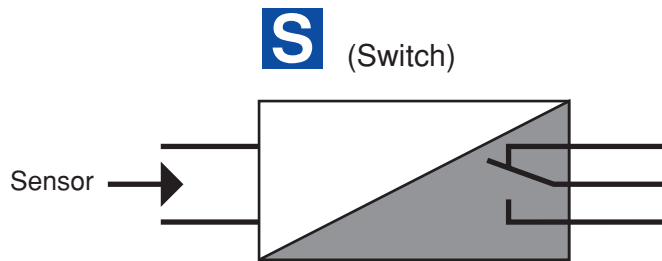
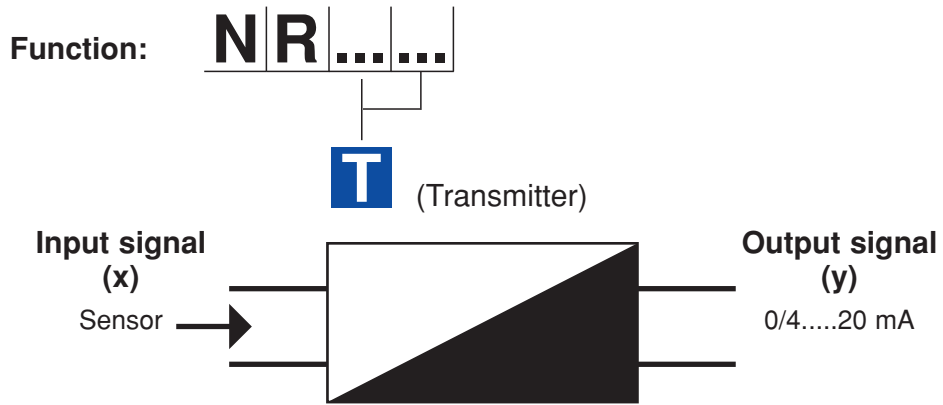

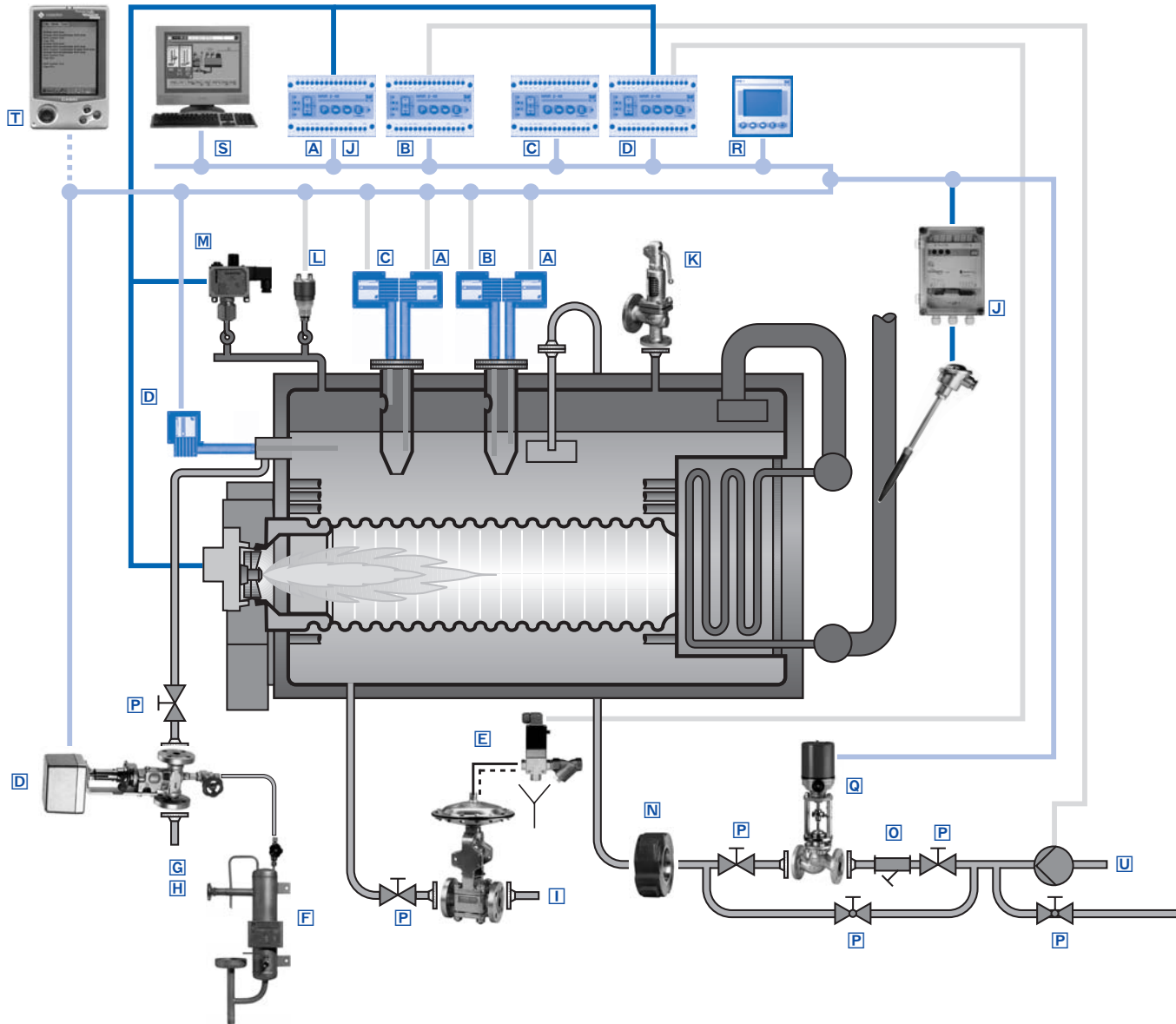

Boiler equipment acc. to TRD 604 (continuous operation without constant supervision for 24/72 hrs) or in accordance with other European guidelines, e. g. EN 12953 part 6

- | | |
|--|---|
| <p>A Self-monitoring
low-level electrode NRG 16-40</p> <hr/> <p>A J Low-level alarm NRS 1-40/NRS 1-40.1</p> <hr/> <p>B R Modulating level control with fully integrated second level and conductivity (TDS) indicator:
level electrode NRG 26-40, level controller NRR 2-40, control terminal and display unit URB</p> <hr/> <p>C Self-monitoring high-level alarm:
level electrode NRG 16-41, level switch NRS 1-41</p> <hr/> <p>D E TDS control / Continuous and intermittent boiler blowdown:
Conductivity electrode LRG 16-40, continuous blowdown controller LRR 1-40, continuous blowdown valve BAE, intermittent blowdown valve MPA, 3/2 way pilot valve, strainer</p> <hr/> <p>F Sample cooler</p> | <p>G Flash vessel</p> <hr/> <p>H Residual blowdown heat exchanger</p> <hr/> <p>I Blowdown receiver (mixing cooler)</p> <hr/> <p>J Self-monitoring temperature limiter:
resistance thermometer TRG 5-65, temperature switch TRV 5-40, NRS 1-40.1 (only with existing superheater)</p> <hr/> <p>K Safety valve GSV</p> <hr/> <p>L Pressure limiter DSH</p> <hr/> <p>M Pressure controller/transmitter</p> <hr/> <p>N DISCO Non-return valve RK 86 A</p> |
|--|---|

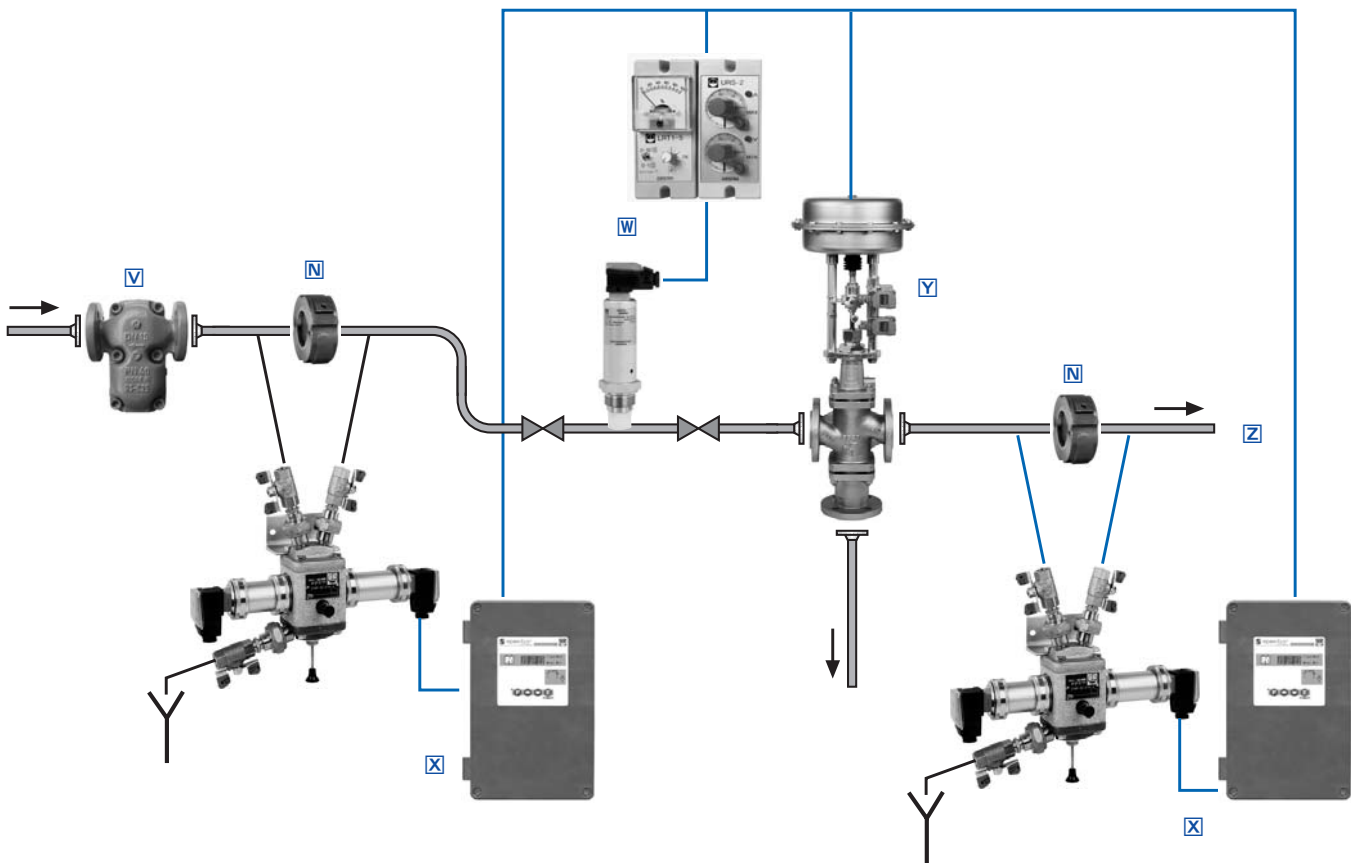

Steam and Condensate System

- Q Strainer GSF

- P Bypass/isolating valve GAV

- Q Electric/pneumatic control valve V 725

- R Control terminal and display unit URB

- S Operating data acquisition

- T Operating data retrieval/ access and commissioning via modem/mobile phone/handheld

- U Feedwater monitoring:
 - ▶ On-line analysis of residual hardness of water
 - ▶ Demineralization plant: TDS control (conductivity monitoring)

- V Steam trap

- W Contamination detectors (ingress of acids, alkalis, etc.): Conductivity electrode LRG 12-1, conductivity transmitter LRT 1-6, max.-min. limit switch URS 2
Alternatively with EC / TÜV approval
 Compact electrode LRGT 16-1
 Controller with MAX contact KS 90

- X Oil and turbidity detector OR

- Y Electric/pneumatic three-way control valve for the discharge of contaminated condensate

- Z Condensate receiver tank

Technologically Advanced Liquid Level Control

With more than 30 years' experience in the design and manufacture of industrial electronics and almost a century in all fields of steam trapping and shut-off valves, GESTRA enjoys a unique position in the industry as a trusted single-source partner for boiler equipment.

Right from the outset GESTRA blazed a trail in advanced boiler safety. In our drive to set new safety standards, we were the first company to team up with the German Technical Supervisory Association TÜV in order to design self-monitoring low-level alarm systems.

Apart from low-level alarms GESTRA now offers an extensive range of electronic boiler equipment for power stations as well as industrial applications.

Our latest, trend-setting innovation is the new Spector equipment featuring advanced bus-based technology, which provides a future-proof framework for decentralized, flexible operations.

Application

	Measurement	
	Capacitance	Conductivity
Steam boilers	●	●
Hot-water boilers	●	●
Steam regenerator	●	●
Condensate tanks	●	●
Feedwater tanks	●	●
Fresh water tanks	●	●
Pump sumps	●	●
Holding tanks	●	●
Product tanks	●	●
Tunnel drainage	●	●
Drainage systems in power stations	●	–
Autoclave drainage	●	●
Pump controls	●	●
Oil detection in cooling-water systems	–	●
Daily service tanks for oil	●	–
Diesel fuel tanks	●	–

Examples of Industrial Applications

Purpose	Application	Principle of measurement	Level electrode	Level switch	Switch point
Level control	Fill or discharge control with protection against pump running dry and high-level alarm	Conductivity meas.	NRGS 1.-1	–	fixed
	Fill or discharge control with protection against pump running dry and high-level alarm	Conductivity meas.	NRG 16-42	NRS 1-42	fixed
	Fill or discharge control with protection against pump running dry and high-level alarm	Conductivity/capacitance meas.	NRG 26-40	NRS 2-40	adjustable
	Modulating fill or discharge control with protection against pump running dry and high-level alarm incl. level indicator	Conductivity/capacitance meas.	NRG 26-40	NRR 2-40/URB	adjustable
	Modulating level detection for remote indication	Conductivity/capacitance meas.	NRGT 26-1	URA 2	–
	Modulating fill or discharge control with protection against pump running dry and high-level alarm	Conductivity/capacitance meas.	NRGT 26-1	KS 92-1	adjustable
	Fill or discharge control with protection against pump running dry and high-level alarm	Conductivity/capacitance meas.	NRGT 26-1	NRS 2-3	adjustable

Boiler operating mode	Low level limiter WB	Feedwater controller WR	High-level alarm HW	First low level alarm	Conductivity sensing electrode	PN	Level electrode	Level switch/controller	Switch-point	On-off control	Modulating control
TRD 701 (max. 1 bar ^{*)})	●	●	–	–		6	NRGS 11-2	–	fixed	●	–
TRD 802 for fast steam generating units	●	●	–	–		40	NRGS 16-2	–	fixed	●	–
TRD 604 without constant supervision – 24 hours	●	–	–	–		40	NRG 16-40 (2x)	NRS 1-40 (1x)	fixed	–	–
	●	–	–	–		63	NRG 17-40 (2x)	NRS 1-40 (1x)	fixed	–	–
	●	–	–	–		160	NRG 19-40 (2x)	NRS 1-40 (1x)	fixed	–	–
	●	–	–	–		320	NRG 111-40 (2x)	NRS 1-40 (1x)	fixed	–	–
	●	–	–	–		40	NRG 16-11 (2x)	NRS 1-7 (2x)	fixed	–	–
	●	–	–	–		63	NRG 17-11 (2x)	NRS 1-7 (2x)	fixed	–	–
	●	–	–	–		160	NRG 19-11 (2x)	NRS 1-7 (2x)	fixed	–	–
	●	–	–	–		320	NRG 111-11 (2x)	NRS 1-7 (2x)	fixed	–	–
	–	●	●	●		40	NRG 16-42	NRS 1-42	fixed	●	–
	–	●	●	●		40	NRGS 16-1	–	fixed	●	–
EN 12953 part 6	–	●	●	●		40	NRG 26-40	NRS 2-40	adjustable	●	–
	–	●	●	●		40	NRG 26-40	NRR 2-40/URB	adjustable	–	●
	–	●	●	●		40	NRGT 26-1	KS 92-1	adjustable	–	●
EN 12952 part 7	–	●	●	●		40	NRG 26-21	NRR 2-2	adjustable	–	●
	–	●	–	–		40	NRG 26-21	NRR 2-1	adjustable	–	●
	–	●	●	●		63	144 LD / 705	KS 92-1	adjustable	–	●
	–	●	●	●		160	144 LD / 705	KS 92-1	adjustable	–	●
TRD 604 72h-Betrieb without constant supervision – 72 hours	●	–	–	–		40	NRG 16-40 (2x)	NRS 1-40 (1x)	fixed	–	–
	●	–	–	–		63	NRG 17-40 (2x)	NRS 1-40 (1x)	fixed	–	–
	●	–	–	–		160	NRG 19-40 (2x)	NRS 1-40 (1x)	fixed	–	–
	●	–	–	–		320	NRG 111-40 (2x)	NRS 1-40 (1x)	fixed	–	–
	●	–	–	–		40	NRG 16-11 (2x)	NRS 1-7 (2x)	fixed	–	–
	●	–	–	–		63	NRG 17-11 (2x)	NRS 1-7 (2x)	fixed	–	–
	●	–	–	–		160	NRG 19-11 (2x)	NRS 1-7 (2x)	fixed	–	–
	●	–	–	–		320	NRG 111-11 (2x)	NRS 1-7 (2x)	fixed	–	–
	–	●	● ¹⁾	●		40	NRG 16-42	NRS 1-42	fixed	●	–
	–	●	● ¹⁾	●		40	NRGS 16-1	–	fixed	●	–
	–	●	● ¹⁾	●		40	NRG 26-40	NRS 2-40	adjustable	●	–
	–	●	● ¹⁾	●		40	NRG 26-40	NRR 2-40 / URB	adjustable	–	●
	–	●	● ¹⁾	●		40	NRGT 26-1	KS 92-1	adjustable	–	●
	–	●	● ¹⁾	●		63	144 LD / 705	KS 92-1	adjustable	–	●
	–	●	● ¹⁾	●		160	144 LD / 705	KS 92-1	adjustable	–	●
	–	–	●	–		40	NRG 16-4	NRS 1-2	fixed	–	–
	–	–	●	–		40	NRG 16-41	NRS 1-41	fixed	–	–
	–	–	●	–		63	NRG 17-41	NRS 1-41	fixed	–	–
	–	–	●	–		160	NRG 19-41	NRS 1-41	fixed	–	–
	–	–	●	–		40	NRG 16-12	NRS 1-8	fixed	–	–
–	–	●	–		63	NRG 17-12	NRS 1-8	fixed	–	–	
–	–	●	–		160	NRG 19-12	NRS 1-8	fixed	–	–	
1 Conductivity sensing electrode					●	40	LRGT 16-1	KS 90	adjustable	●	●
					●	63	LRGT 17-1	KS 90	adjustable	●	●
					●	40	LRG 16-40	LRR 1-40 / URB	adjustable	●	●
					●	63	LRG 17-40	LRR 1-40 / URB	adjustable	●	●
						63	LRG 17-1	LRR 1-5 / URS 2	adjustable	●	–
					160	LRG 19-1	LRR 1-5 / URS 2	adjustable	–	–	

^{*)} according to PED max. 0.5 bar

¹⁾ Only as first alarm.

Low-level limiter and feedwater control electrodes or low-level limiter and high-level alarm electrodes can be installed together in one flange.

GESTRA Boiler controls acc. to TRD 604, sheet 1, 24/72 hrs or EN 12953, part 6 TÜV, EC Type Approval Revised: February 2004

Function	TRD 604			EN 12953, part 6			Equipment	Type approval no.
	required	recommended	Section	required	recommended	Section		
2 Low-level limiters	yes		1.4 3.6.1	yes		4.3.1 5.7.1	NRG 16-40 / NRS 1-40 Self-monitoring equipment with automatic routine testing	TÜV-SWB/SHWS-02-403 EG BAF-MUC 02 02 103881 002
							NRG 16-11 / NRS 1-7 Self-monitoring equipment with automatic routine testing	TÜV WB 01-354 EG 01 202 931-B-01- 0007
Low-level limiter/ High-level alarm in Bus system	yes		1.4 3.6.1 1.8 5.1	yes		4.3.1 5.7.1	NRG 16-40 / NRS 1-40 Self-monitoring equipment with automatic routine testing NRG 16-41 / NRS 1-41 Self-monitoring equipment with automatic routine testing	TÜV-SWB/SHWS-02-403 EG BAF-MUC 02 02 103881 002
Low-level limiter/ High-level limiter/ Temperature limiter	yes		1.4 3.6.1 1.8 5.1 1.6 1.7 3.63	yes		4.3.1 5.7.1 4.4 5.7.2	NRG 16-40 Self-monitoring equipment NRG 16-41 Self-monitoring equipment TRG / TRV 5-46 Self-monitoring equipment NRS 1-40.1	TÜV-SWB/SHWS-03-413 EG BAF-MUC 03 07 103881 004
Low-level limiter with control/ High level	yes		1.4 1.8 3.4	yes		4.3.1 5.7.1 4.5.2	NRG 16-36 / NRS 1-9 Self-monitoring equipment with automatic routine testing	TÜV WB/WR 04-370 EG 01 202 931-B01- 0075
Feedwater controller with high-level alarm	yes		1.8 3.4	yes		4.5.2 5.5 5.6.1 5.6.2	NRGS 16-1 Compact system for on-off control	TÜV WRB 01-388
							NRG 16-42 / NRS 1-42 Bus-based on-off control	TÜV WR 03-399
							ER 56 / NRS 1-5 On-off control - discontinued -	TÜV WR 03-302
							NRGT 26-1 Compact system for continuous monitoring, current output 4...20 mA	TÜV WR 02-391
							NRG 26-40 / NRS 2-40 Bus-based on-off controller with adjustable switchpoints	TÜV WR 03-399
							NRG 26-21 / NRS 2-1 On-off control - discontinued - with adjustable switchpoints	TÜV WR/WS 04-317
							NRG 26-40 / NRR 2-40 URB Bus-based modulating controller with adjustable limits	TÜV WR 03-399
Feedwater controller with high-level alarm	yes		1.4 3.4	yes		4.5.1 5.5 5.6.1 5.6.2	NRG 26-21 / NRR 2-1 Modulating control - discontinued -	TÜV WR 04-317
							NRG 26-21 / NRR 2-2 Modulating control with adjustable limits - discontinued -	TÜV WR 01-320
							LD 144	TÜV WRS 01-324
Separate high-level alarm	yes »72h«		1.8 5.1			5.6.2	NRG 16-4 / NRS 1-2 Conventional design	TÜV WR
							NRG 16-12 / NRS 1-8 Self-monitoring equipment with automatic routine testing	TÜV approval 01-91-0112
							NRG 16-41 / NRS 1-41 Self-monitoring equipment with automatic routine testing	TÜV-SWB/SHWS-02-403 EG BAF-MUC 02 02 103881 002

According to TRD regulations you may only combine low-level limiters with level controls or high-level alarms.

GESTRA Boiler controls acc. to TRD 604, sheet 1, 24/72 hrs or EN 12953, part 6 TÜV, EC Type Approval Revised: February 2004

Function	TRD 604			EN 12953, part 6			Equipment	Type approval no.
	required	recommended	Section	required	recommended	Section		
Safety temperature limiter	yes		1.6 1.7 3.6.3	yes		4.4 5.7.2	TRG 5-5./6 / TRV 5-40 NRS 1-40.1	in preparation
Safety temperature limiter	yes		1.7 1.6 3.6.3	yes		5.7.2 4.4	TRG 5-5.. / TRS 5-6 PT 100	STW (STB) 985 98 S EG 01 202 931-B-01-0008
							TRG 5-... / TRS 5-7 Thermocouple type K	STW (STB) 986 98 S EG 01 202 931-B-01-0007
Safety pressure limiter	yes		1.3 3.6.4	yes		5.7.2	DSF ..F 001 Self-monitoring equipment	TÜV DWFS (SDBFS) 00-332
Conductivity (TDS) control for boiler water*)	yes		5.2				LRG 16-4 / LRS 1-5 manual temperature compensation	not available TÜV approval
Automatic continuous boiler blowdown system*)	optional	yes	2.1 4.8		yes	C 1.8	LRG 16-4 / LRS 1-5 On-off control	not required
							LRGT 16-1 / KS 90 Three-position stepping control, automatic temperature compensation	TÜV-WÜL-01-003 EG BAF-MUC 01 04 105620 001
Automatic continuous boiler blowdown with signaling of limit levels*) ¹⁾	optional yes »72h«	yes	5.2		yes	C 1.8	LRG 16-4 / LRR 1-5 / URS 2 On-operation-off manuel temperature compensation	not available
							LRGT 16-1 / KS 90 Three-position stepping control, automatic temperature compensation Max. limit	TÜV-WÜL-01-003 EG BAF-MUC 01 04 105620 001
							LRG 16-40 / LRR 1-40 Bus-based continuous boiler blowdown, three-position stepping control, automatic temperature compensation Max. limit	TÜV-WÜL-02-007 EG BAF-MUC 02 03 103881 003
Automatic intermittent boiler blowdown	optional	yes	2.1/5.2 4.8		yes	5.3.1	TA / MPA	not required
Conductivity (TDS) control for make-up water*)	yes »72h«		2 4.8 5.2				LRG 16-4 / LRS 1-6	not available
Residual hardness of make-up water (process titration*)	yes »72h«		5.2					
Condensate monitoring: oil and turbidity detection*)	yes »72h« 2 detectors		2.1/4.8	yes		5.6.3	OR 52-5 / -6	TÜV-WÜF-02-009
			5.2					
Contamination detection of acids, alkalis etc.*)	yes		2.1/4.8 5.2	yes		5.6.3	LRG 12-1 / LRT 1-6 URS 2	not available

Explanatory notes:

* Approximate values and limits according to TRD 611 / EN 12952-12 and EN 12953-10

1) Combining continuous boiler blowdown and limit control precludes the need for pure limit signalling.

T.D.S. = Total Dissolved Solids

Type Approval Number Code

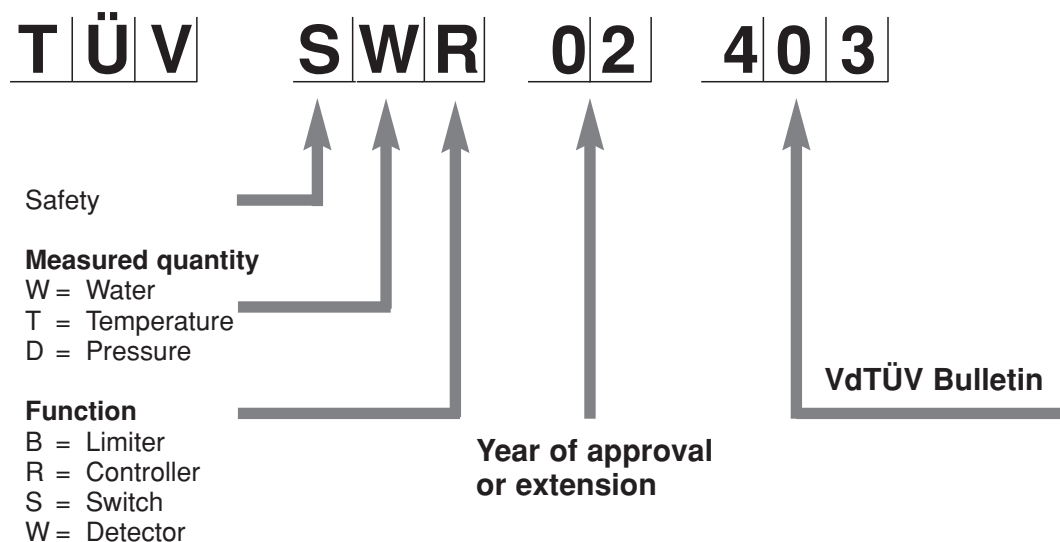

Classification societies for marine applications

- GL Germanischer Lloyd
- LR Lloyd's Register
- See BG See-Berufsgenossenschaft
- RINA Registro Italiano Navale
- NKK Nippon Kaiji Kyokai
- ABS American Bureau of Shipping
- KR Korean Register of Shipping
- BV Bureau Veritas
- DNV Det Norske veritas

Abbreviations for temperature control equipment:

- STW = Safety temperature controller
- (STB) = Safety temperature limiter designed with interlocking facility
- TW = Temperature controller

Function	Equipment	Type Approval Number
Water-level controller with high-level alarm	NRGS 16-1S Compact system for on-off control	GL99250-96 HH LR 98/20075 RINA No ELE/30298/1
	NRGT 26-1S KS 92-1 NRS 2-3 Compact system for modulating control, current output 4...20 mA	GL 99249-96 HH LR 98/20074 RINA No ELE/30298/2 KR HMB06190-MS002 DNV A-8394
Water-level limiter	NRG 16-11S NRS 1-7 Self-monitoring equipment with automatic routine testing	LR 98/20076 GL WB-93-349001 RINA No ELE/95695/1 KR HMB06190-MS002 NKK 02A012
Combination electrode 2 Water-level limiters	NRG 16-38S NRS 1-7	LR 01/20026 GL 40 601 - 01 HH ABS 01-HG227959-PDA
Combination electrode 2 Water-level limiters	NRG 16-39S NRS 1-7 (2x) Self-monitoring equipment with automatic routine testing combined with compact system for continuous monitoring current output 4...20 mA	KR HMB06190-MS002 NKK 02A013 DNV A-8394 BV 11400/A1 BV
Safety temperature limiter	TRG 5-5../TRS 5-6	GL 99251-96 HH LR 00/20051

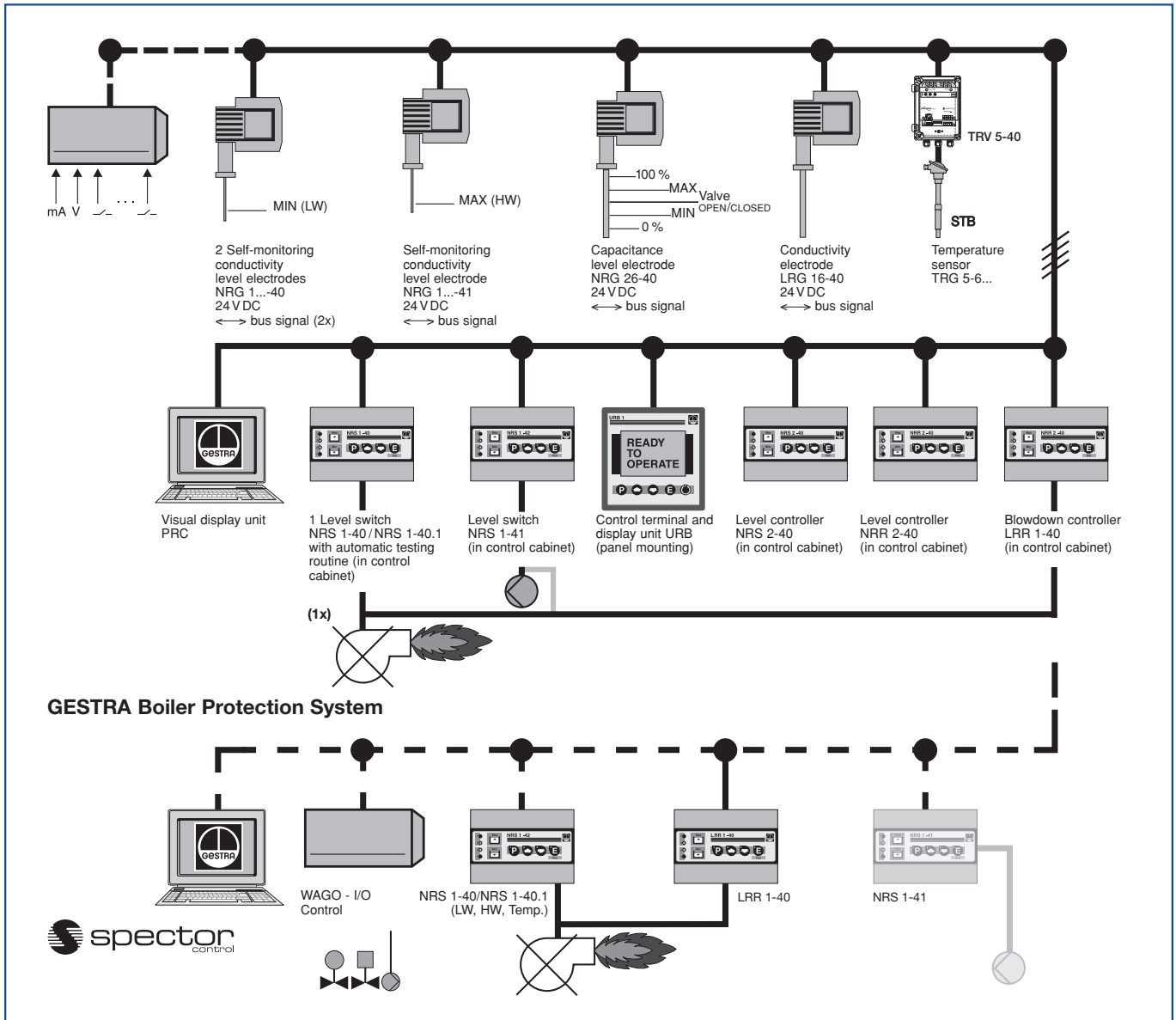

Spector BUS

With these systems, proven technology in the design of electrodes has been alloyed with innovative new level detection and evaluation techniques:

All level electrodes feature now special electronic sensor units which, via a bus interface, can exchange data automatically with level controllers or higher-level control systems.

The next era in liquid level monitoring and control has dawned.

Features and Benefits of Spector BUS

- Patented thermal barrier in cylindrical body above electrode flange
- Terminal box equipped with excess temperature fuse (85°C)
- Freely accessible connecting terminals
- Large terminal box makes for easy installation
- Standardized response sensitivity $\geq 0.5 \mu\text{S/cm}$ simplifies stocking and spare part inventories
- Optimum system adaptation/extension without any additional wiring
- Reduced installation effort and material costs, since only a single four-core cable is required between boiler and control cabinet
- Active cable monitoring through message identification for error detection and prioritisation of messages in the event of low-level alarm
- Reduced cost of control cabinet
 - only one PG thread
 - only five input terminals
 - only one cable in control cabinet for **all** sensing units
- Length of cable between sensor and controller 125 m; max. cable length 1000 m
- Easy to integrate in visual display and automation systems
- Thanks to increased functionality of controllers less component parts required
- **Limitier**
 - Two electrodes but only **one** controller
 - Switch-selectable one/two-electrode system (emergency operation)
 - Instantaneous indication of low level by separate, flashing diode as soon as the liquid falls below low level (simplifies routine testing)
 - After time delay has elapsed, the LEDs stop flashing and are permanently illuminated
 - Separate, instantaneous signal output for low water level
 - Self-test routine **combined with** automatic self-checking of respective output relay contacts
- **GESTRA Boiler Protection System**
 - up to 4 limiters for one control unit (2 x LW, HW, temp.).
- **Controller**
 - Less time-consuming calibration of measuring range; 100 % can be adjusted at level 50 %.
 - No additional time relays required for system optimization. Built-in time delays individually adjustable between 1...25 sec. for **each** contact and position.
 - Reduced wiring effort for control cabinet: Only a single four-core cable is required for wiring the panel-mounted control terminal and display unit, since all switchgear controls remain on the mounting panel where their functions are required.
 - **One** operating and control terminal for **all** connected bus nodes.
 - The control terminal features permanent level and conductivity indication according to TRD 401 (second water-level indication) and draft of rules concerning conductivity limiters.
 - Easy parameterization of controls on control terminal or PC.

Level Limitation

Low-Level Limiter

Control unit NRS 1-40 in conjunction with **one** level electrode type NRG 16-40, 17-40, 19-40 or 111-40 constitutes a high-integrity self-monitoring low-level limiter with periodic self-checking and automatic routine testing of output relay contacts.

- Low-level alarm with **one** switchpoint.

The equipment detects min. water level (low-level alarm).

Application in steam and pressurized hot-water boilers according to TRD 401, TRD 602 and TRD 604, EN 12952/..53.

Control unit NRS 1-40 in conjunction with **two** level electrodes type NRG 16-40, 17-40, 19-40 or 111-40 constitutes a high-integrity self-monitoring low-level limiting **system** with periodic self-checking. The control unit features the following function:

- Low-level alarm with **two** switchpoints.

The equipment combination detects low-water level (low-level alarm **system**).

Application in steam and pressurized hot-water boilers according to TRD 604, sheet 1 and 2 (operation

without constant supervision for 24/72 hrs.).

The electric device complies with the regulations for safety circuits to DIN VDE 0116 (prEN 50156)

The liquid level data are transferred from the electrode NRG 1...-40 to the control unit via CAN bus, using the CANopen protocol.

The safety temperature limiter type TRG 5-6./TRV 5-40 can be added to the system; for more information refer to page 107.

High-Level-Alarm

Low-Level Limiter

Control unit NRS 1-41 in conjunction with **one** level electrode type NRG 16-41, 17-41 or 19-41 constitutes a high-integrity self-monitoring high-level alarm system with periodic self-checking and automatic routine testing of output relay contacts. Function:

- High-level alarm

The equipment detects the max. water level.

Application in steam and pressurized hot-water boilers according to TRD 401, TRD 602 and TRD 604, EN 12952/..53.

The electric device complies with the regulations for safety circuits to DIN VDE 0116 (prEN 50156).

The liquid level data are transferred from the electrode NRG 1...-41 to the control unit via CAN bus, using the CAN open protocol.

Boiler Protection System

Description

The control unit NRS 1-40.1 in combination with **two** level electrodes NRG 1.-40, the temperature sensor TRG 5-6./TRV 5-40 and, if required, the level electrode NRG 1.-41 constitutes a self-monitoring boiler protection system with periodic self-testing and continuous monitoring of the output relays. The control unit features the following functions:

- Low-level alarm with **two** switchpoints

The equipment combination detects the min. water level (low-level limiting **system**).

- Safety temperature limiter

The equipment combination detects the max. allowable temperature.

- High-level alarm

The equipment combination detects the max. water level.

Application in steam and (pressurized) hot water plants in accordance with TRD 604, sheet 1 and sheet 2 (24/72 hrs operation).

The electrical equipment meets the requirements of the regulations for safety circuits according to DIN VDE 0116 (prEn 50156).

The data of the sensors are transferred to the control unit via CANbus, using the CANopen protocol.

**Self-monitoring low-level alarm system to TRD 604
(24/72 hrs without constant supervision)/EN 12952/53**

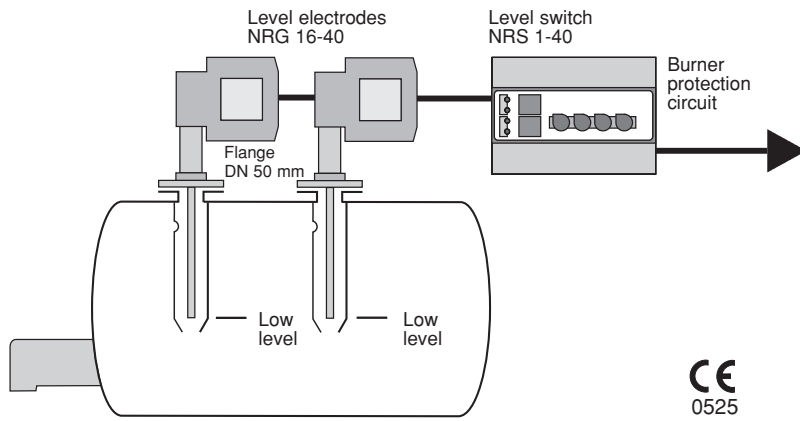

Type	PN	Stock code
NRG 16-40 1000 mm	40	3514042
NRS 1-40 230 V		3222541
NRG 17-40 1000 mm	63	3544042
NRS 1-40 230 V		3222541
NRG 19-40 1000 mm	160	3574042
NRS 1-40 230 V		3222541
NRG 111-40 1000 mm	320	3574142
NRS 1-40 230 V		

Type approval
TÜV SWB/SHWS · 02-403
EG BAF-MUC 02 02 103881 002

If supervision is limited, the system can be operated with one electrode.

**High-level alarm
TRD 604, 72h**

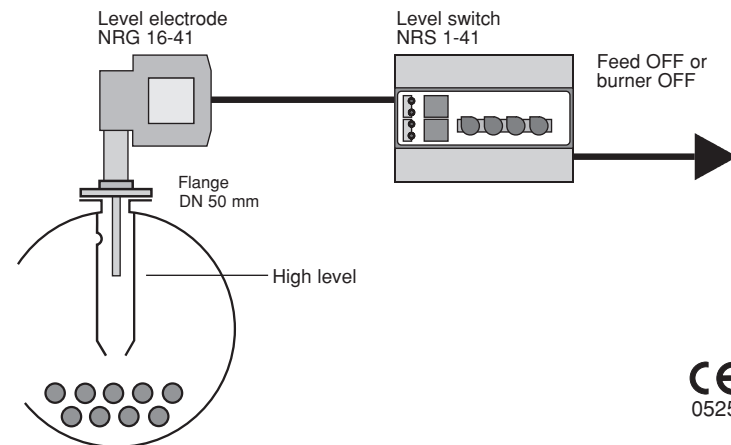

Type	PN	Stock code
NRG 16-41 500 mm	40	3524041
NRS 1-41 230 V		3222741
NRG 17-41 500 mm	63	3554041
NRS 1-41 230 V		3222741
NRG 19-41 500 mm	160	3594041
NRS 1-41 230 V		3222741

Type approval
TÜV SWB/SHWS · 02-403
EG BAF-MUC 02 02 103881 002

Optional: NRS 1-4.
special voltage: 115 V, 24 V, 50..60 HZ

**Self-monitoring boiler protection system
TRD 604 24h/72h / EN 12952/53**

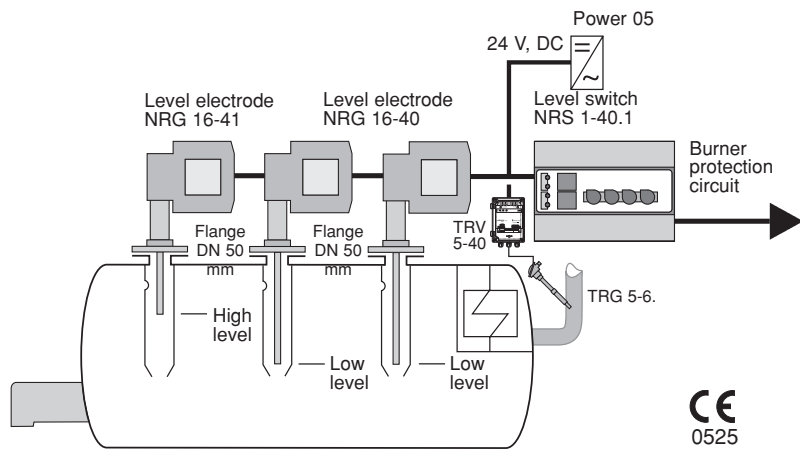

Type	PN	Stock code
NRG 16-40 1000 mm	40	3514042
TRG 5-65		
TRV 5-40		
NRG 16-41 500 mm	63	3524041
NRS 1-40.1 230 V		3222841
NRG 17-40 1000 mm	160	3544042
TRG 5-65		
TRV 5-40		
NRG 17-41 230 V	320	3551241
NRS 1-40.1 230 V		3222841
NRG 19-40 1000 mm	320	3574042
TRG 5-65		
TRV 5-40		
NRG 19-41 500 mm	320	3594041
NRS 1-40.1 230 V		3222841
NRG 111-40 1000 mm	320	3574142
TRG 5-65		
TRV 5-40		
NRG 111-41 230 V	320	3222841
NRS 1-40.1 230 V		

Type approval
TÜV SWB/SHWS · 03-413
EG BAF-MUC 02 02 103881 004
TRG 5-6... / TRV see pages 106-107.

Description

1. Conductivity Measurement

NRG 16-42

The level electrode type NRG 16-42 works according to the conductivity measurement principle. With the NRG 16-42 a maximum of four levels can be signalled in conductive liquids:

- Four levels with one switchpoint each
- High-level alarm, first low-level alarm, pump ON, pump OFF, with one switchpoint each

Use level electrode NRG 16-42 in combination with level switch type NRS 1-42 or other system components. The level data are transferred to the level switch or any other system component via a CAN data bus.

NRS 1-42

Use level switch type NRS 1-42 in combination with level electrode type NRG 16-42 for level monitoring. The level switch has the following functions:

- Four levels with one switchpoint each
- High-level alarm, first low-level alarm, pump ON, pump OFF, with one switchpoint each

The level data are transferred from the electrode NRG 16-42 to the level switch via a CAN bus.

2. Capacitance Measurement

NRG 26-40

The level electrode NRG 26-40 works according to the capacitance measurement principle.

The NRG 26-40 is used for detecting and signalling different levels in conductive and non-conductive liquids:

- Level always within defined measuring range of electrode.

Use level electrode NRG 26-40 in combination with level switch type NRS 2-40 or further system components. The level data are transferred to the level switch or any other system component via the CAN data bus.

NRS 2-40

Use level switch type NRS 2-40 in combination with level electrode type NRG 26-40 for level control and monitoring. The level switch has the following functions:

- Four liquid levels with one switchpoint each
- High-level alarm, first low-level alarm, pump ON, pump OFF, with one switchpoint each

The level switch NRS 2-40 can be optionally equipped with an actual value output for standard signal 4-20 mA.

The level data are transmitted from the electrode NRG 26-40 to the level switch via a CAN data bus.

If you want to connect a second NRS 2-40 in order to establish additional switchpoints please indicate this when ordering.

NRR 2-40

Use level controller NRR 2-40 in combination with level electrode type NRG 26-40 for level control and monitoring. The level controller has the following functions:

- Two limit values with one switchpoint each (high-level alarm and first low-level alarm)
- Three-position or modulating control within a predefined proportional band

- All contacts feature time delays adjustable between 1 – 25 sec.
- Continuous level monitoring within defined measuring range of the electrode.

The NRR 2-40 features an optional output for standard signal 4-20 mA, which can be used for actual value and/or modulating control. The level data are transferred from the electrode NRG 26-40 to the level controller via a CAN data bus.

URB

The URB is a user-friendly control terminal and display unit for use with GESTRA CAN bus systems. With the URB all standard functions of the CAN bus system can be easily called up and adjusted. Furthermore, the URB makes the parameterization of the controller very convenient: The switchpoints and the proportional band can be adjusted by means of the keypad regardless of the actual level. The energizing and de-energizing times of the relays can be customized for the individual switchpoints.

The LCD of the URB displays the following:

- Current liquid level (second water level) (TRD 401, EN 12952, ...53)
- Current conductivity value (TSD control)
- Proportional band of controller (NRR 2-40), (LRR 1-40)
- Switchpoints
- Position and value of switchpoint LOW LEVEL
- Position and value of switchpoint HIGH LEVEL
- Position of set point (NRR 2-40), (LRR 1-40)
- Deviation
- Valve position
- Manual/automatic operation
- Current CAN bus address
- Indication of high/low level alarm

**On-off control with fixed switchpoints
Spector BUS system**

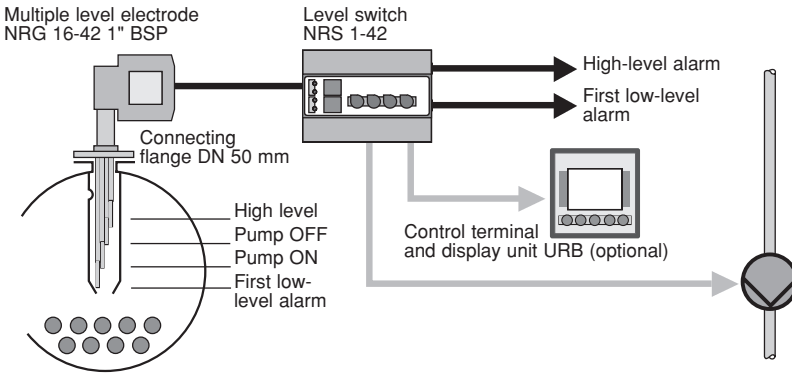

Type	PN	Stock code
NRG16-42 L=1000 mm	40	353 42 48
NRS 1-42 230 V		322 22 41
Optional: URB VDU		338 10 43

Optional 115 V, 50..60 Hz

Type approval
TÜV · WR · 03-399

**On-off control with adjustable switchpoints
Spector BUS system**

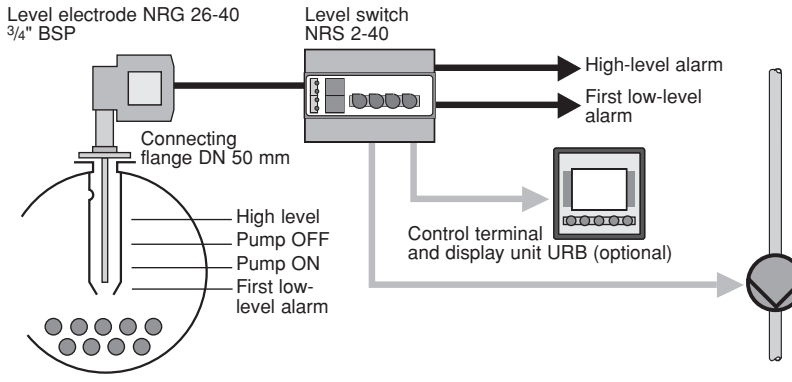

Type	PN	Stock code
NRG26-40 H=1000 mm	40	348 40 47
NRS 2-40 230 V		322 30 41
Optional: URB VDU		338 10 43

NRS 2-40 optional
115 V, 50..60 Hz

Actual value output 4-20 mA .57
Second device .59

Type approval
TÜV · WR · 03-399

**Modulating control with high and first low level alarm
Spector BUS system**

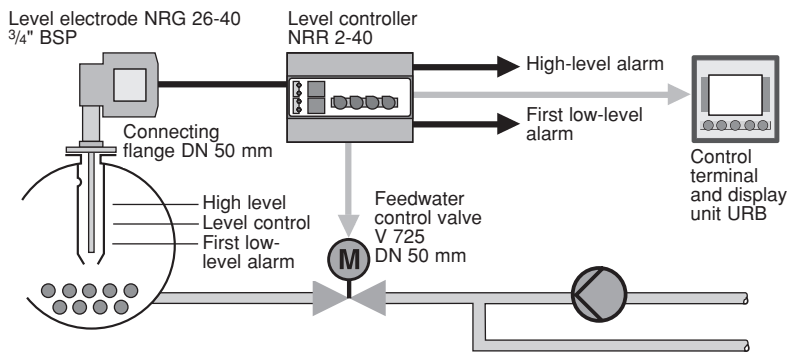

Type	PN	Stock code
NRG26-40 H=1000 mm	40	348 40 47
NRR 2-40 230 V		322 50 41
Optional: URB VDU		338 10 43

NRR 2-40 optional
115 V, 50..60 Hz

Actual value output 4-20 mA .57
Output for continuous
controller 4-20 mA .58

Type approval
TÜV · WR · 03-399

Spector Compact

Where formerly two devices were required, all you need now is just a single Spector compact. As a combined level electrode and controller, it presents the economical alternative for monitoring liquid levels in small installations and steam boilers.

Since the entire electronic control unit is located within the terminal box, the transmission path is short and reliability is higher than for comparable systems.

Features and Benefits

- Patented temperature barrier in cylindrical body above electrode flange
- Terminal box equipped with excess temperature fuse (102 °C)
- Level electrode and controller in one unit
- Optimum system adaptation thanks to modular design
- No mounting of component parts in control cabinet
 - No space requirements
 - No installation
 - No wiring
 - Easy planning
- No special cable required for wiring sensing unit to control cabinet

System Description NRGs 1...-1

The compact system NRGs 11-1 or NRGs 16-1 works according to the conductivity measurement principle. With the NRGs 1...-1 a maximum of **four** levels can be signalled in conductive liquids:

- High-level alarm, first low-level alarm, pump ON, pump OFF, with one switchpoint each.

The NRGs 1...-1 has a level switch integrated in the electrode case for the control of all functions. An external switching device is **not** required.

System Description NRGs 1...-2

The compact system NRGs 11-2, NRGs 16-2 works according to the conductivity measurement principle. With the NRGs 1...-2 a maximum of **three** levels can be signalled in conductive liquids:

- Low-level alarm, pump ON, pump OFF, with one normally open contact.

The NRGs 1...-2 has a level switch integrated in the electrode case for the control of all functions. An external switching device is **not** required.

The NRGs 1...-2 has two electrode tips for the detection of low-water level. The low-level alarm is signalled via two separate switching channels.

- Simplified logistics
 - Only one item of equipment has to be ordered and checked upon receipt
 - Reduced inventory requirements and simplified stocking
 - No onerous assignment procedures of individual component parts to mechanical engineering dept. (boiler) and measurement and control engineering dept. (control cabinet)
- Interchanges with old float-operated systems since they have their output contacts also integrated in the terminal box

System Description NRGT 26-1

The compact system NRGT 26-1 works according to the capacitance measurement principle. The NRGT 26-1 is used for signalling different levels in conductive and insulating liquids.

- Modulating control ensures that the liquid level is always within the predefined measuring range of the electrode.

The NRGT 26-1 has a level transmitter integrated in the electrode case which produces a standard analogue output of 4 – 20 mA. An external switching device is **not** required.

Pump Control Units

Standard features	Type	NRSP 1-11	NRSP 1-12
Pump protection against running dry		●	●
Pump protection against running dry and high-level alarm		–	–
Time-dependent pump switching device		–	●
Switching-on of stand-by pump		–	–
Collective malfunction alarm (visible)		●	●
Collective malfunction alarm (visible and audible)		–	–
Volt-free contacts		●	●
Remote level indication		–	–

Compact system for on-off level control with fixed switchpoints

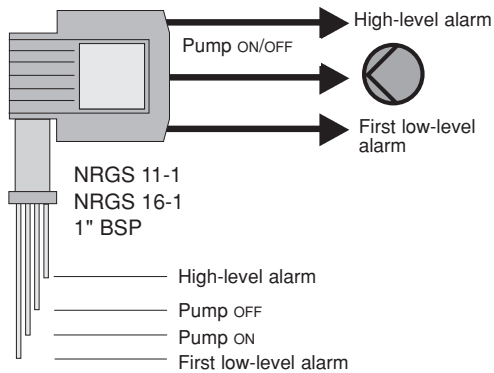

Water-level controller with two additional limit contacts, power supply 115/230 V, 50 Hz.

Type	PN	Max. length supplied	Stock code
NRGS 11-1	6	1000	353 20 48
		1500	353 20 54
NRGS 16-1	40	1000	353 30 48
		1500	353 30 54

Optional 24 V, 50..60 Hz .51

Type approval
TÜV · WRB · 01-388

Compact system for water-level limitation and on-off control

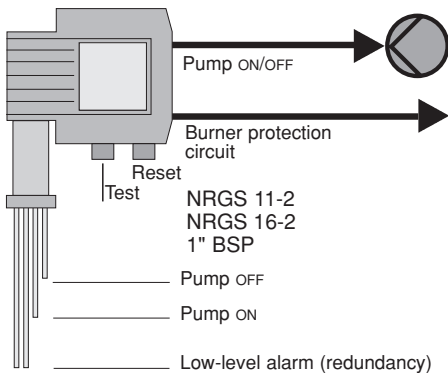

Low-level alarm and liquid level controller, power supply 115/230 V, 50 Hz.

Type	PN	Max. length supplied	Stock code
NRGS 11-2	6	1000	353 21 48
		1500	353 21 54
NRGS 16-2	40	1000	353 31 48
		1500	353 31 54

Optional 24 V, 50..60 Hz .51

Type approval
TÜV · WR/WB · 02-392

Compact system for modulating level control

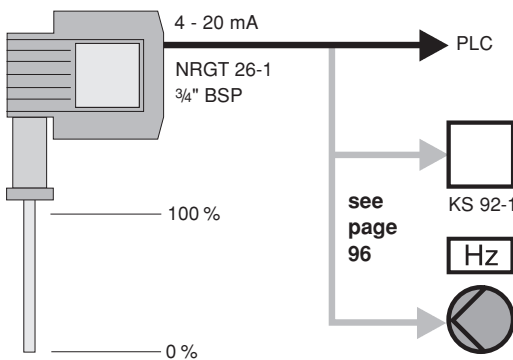

Modulating level control with current output 4 – 20 mA, power supply 115/230 V, 50 Hz.

Type	PN	Max. length supplied	Stock code
NRGT 26-1	40	300	348 10 40
		400	348 10 41
		500	348 10 42
		600	348 10 43
		700	348 10 44
		800	348 10 45
		900	348 10 46
		1000	348 10 47
		1100	348 10 48
		1200	348 10 49
		1300	348 10 50
1400	348 10 51		
1500	348 10 52		
2000	348 10 53		

Optional 24 V, 50..60 Hz .55

Type approval
TÜV · WR · 02-392

Pump control

NRGS 11-1 1" BSP

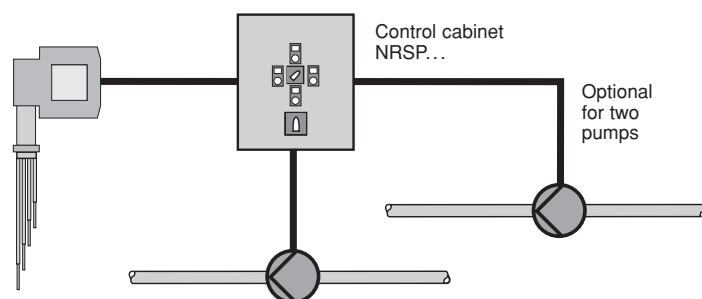

Equipment	Stock code
NRGS 11-1 / NRSP 1-11	353 20 48 / 326 11 40 ...
NRGS 11-1 / NRSP 1-12	353 20 48 / 326 12 40 ...

L = 1000 mm/H = 1000 mm

Description

Low-level limiter

NRG 16-11/NRS 1-7 b

Application and Purpose

Use self-monitoring low-water limiter with periodic self-checking type NRG 16-11 in combination with level switch NRS 1-7 in steam boilers and hot-water plants. The equipment meets the German regulations for use in steam boiler plants operating without constant supervision (TRD 604 sheet 1 and 2).

For boiler operation acc. to TRD 604 two self-monitoring low-level limiters are required and for boiler operation to TRD 602 only one self-monitoring low-level limiter is necessary.

The level electrode NRG 16-11 can be combined with the following GESTRA systems:

- NRG 26/NRR 2-2 (modulating level control)
- NRG 26/NRR 2-1 (modulating level control)

- NRG 26/NRS 2-1 (on-off level control)
- ER 56/NRS 1-5 (on-off level control)
- NRG 16-4/NRS 1-2 (high-level alarm)
- NRG 16-12/NRS 1-8 (self-monitoring high-level alarm)

The level electrode NRG 17-11 can be combined with the following GESTRA systems:

- NRG 17-12/NRS 1-8 (high-level alarm)

The level electrode NRG 19-11 can be combined with the following GESTRA systems:

- NRG 19-12/NRS 1-8 (high-level alarm)

The installation of two low-level alarms in one standpipe is not permissible according to TRD.

Low-level limiter and controller NRG 16-36/NRS 1-9

Application and Purpose

Level controller and self-monitoring low-water level limiter with periodic self-checking feature to be used in conjunction with level electrode NRG 16-36 for on-off boiler feedwater control, high level detection (alarm) and low-water level limiting (min. level alarm). Application in steam and pressurized hot-water boiler installations in accordance with TRD 602 and TRD 604, sheet 1 and 2.

Switching Controller NRS 1-9 b

Plug-in unit in plastic case for installation in control cabinets. The terminals are accessible after unplugging the unit from its base. The plug-in unit may be snapped onto a 35 mm supporting rail or screwed into position on a mounting panel. Field enclosures for several plug-in units are available on request.

High-Level Alarms

Description

“Conventional Design”

NRG 16-4/NRS 1-2

Application and Purpose

Use in combination with level switch NRS 1-2 for water-level limiting (low-level alarm), on-off liquid control and signalling of levels of conductive liquids. The stainless steel design is particularly suited for aggressive fluids. For vessels and steam boilers up to PN 40 with level switch in accordance with TRD 604 (boiler operation without constant supervision).

Sensing unit for high-level alarm and level control.

Design

The level electrode NRG 16-4 is available with screwed connection 3/8" BSP

Material: X 6 CrNiMoTi 17 12 2 (DIN no. 1.4571)

The electrodes are supplied in different lengths (see data sheet). For switching levels between these dimensions the electrode tip can be cut to length as required. Wiring to the electrode is effected by a four-pole connector.

“High-Integrity Design”

NRG 16-12/NRS 1-8

Application and Purpose

Use in combination with level switch NRS 1-8 as self-monitoring high-level alarm with periodic self-checking according to TRD 604 sheet 1 and 2 for high-water level detection (high-level alarm) in steam and pressurized hot-water boilers.

Design

The high-level limiting system comprises level electrode NRG 16-12, NRG 17-12 or NRG 19-12 and level switch NRS 1-8.

The level electrodes NRG 16-12, NRG 17-12 and NRG 19-12 consist of a measuring electrode fitted in a body. The electrode is insulated by special insulating seals.

The pressure-tight connection of the electrode is effected coaxially with a contact ring and a stud. A system of compression springs in the electrode body ensures sufficient sealing forces at the insulating seals, even if temperatures vary. The stud is insulated by a PTFE foil. Contact ring and body are connected to the four-pole connector base by PTFE insulated wires. The level electrode is available in various lengths up to 1500 mm. Observe mounting instructions (see examples of installation). The system (electrode + level switch) complies with the regulations concerning protection circuits for firing equipment of furnaces in accordance with DIN 57116/VDE 0116

Self-monitoring low-level limiter

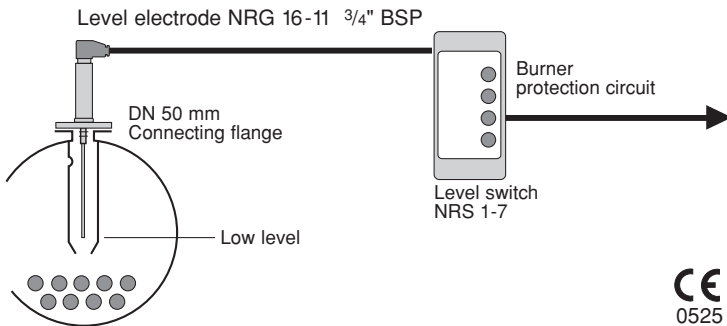

Type	PN	Stock code
NRG 16-11, L = 1000 mm NRS 1-7 230 V	40	3511042 3232541
NRG 17-11, L = 1000 mm NRS 1-7 230 V	63	3541042 3232541
NRG 19-11, L = 1000 mm NRS 1-7 230 V	160	3571042 3232541
NRG 111-11, L = 1000 mm NRS 1-7 230 V	320	3571142 3232541

Type approval
TÜV · WB/WR · 01-354
EC 01 202 931-B-01-0077

Low-level limiter, on-off control and high-level alarm

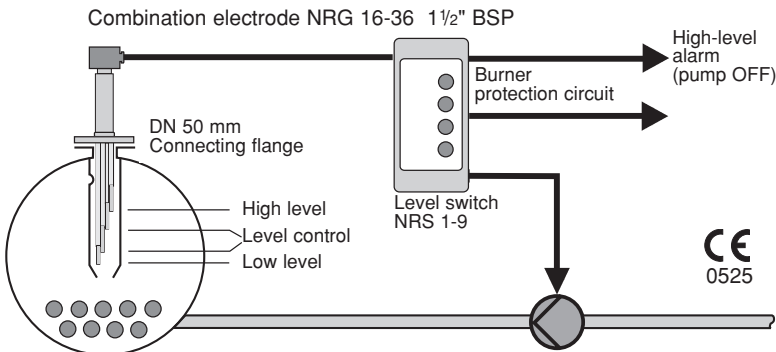

Type	PN	Stock code
NRG 16-36, L = 1000 mm NRS 1-9 230 V	40	3581047 3232841

Type approval
TÜV · WB/WR · 99-370
EC 01 202 931-B-01-0075

Optional voltages for NRS 1-7, NRS 1-9:
115 V, 24 V, 50..60 HZ

High-Level Alarms – Conventional Design

High-level alarm (conventional design)

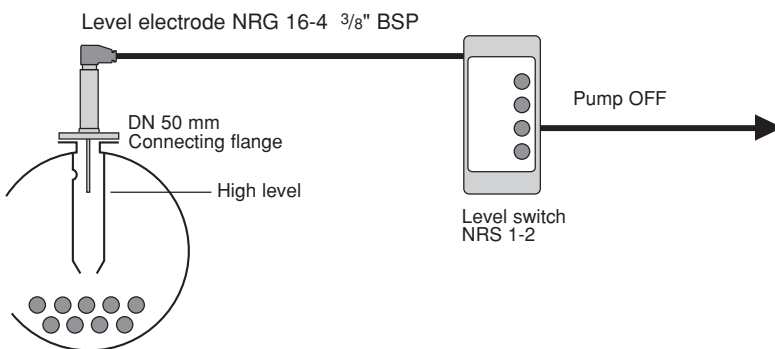

Type	PN	Stock code
NRG 16-4, L = 1000 mm NRS 1-2 230 V	40	3441241 3231441

Type approval
TÜV · WR · 03-302

Self-monitoring high-level alarm

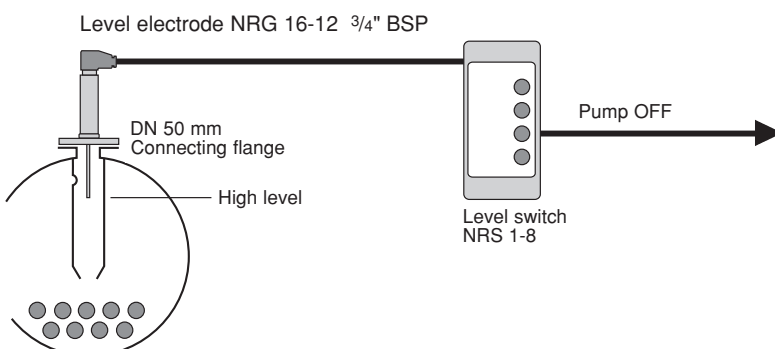

Type	PN	Stock code
NRG 16-12, L = 500 mm NRS 1-8 230 V	40	3521041 3232741
NRG 17-12, L = 500 mm NRS 1-8 230 V	63	3551041 3232741
NRG 19-12, L = 500 mm NRS 1-8 230 V	160	3591041 3232741

Test approval no.
01-91-0112

Optional voltages for NRS 1-2, NRS 1-8:
115 V, 24 V, 50..60 HZ

Description

Level control NRG 26-21 / NRR 2-2e

This modulating level control system comprises the level electrode NRG 26-... and the level controller NRR 2-2.

The level-dependent actual value sensed by the electrode is continuously compared by the controller with the adjusted setpoint. Any deviation is immediately detected and a signal is transferred to the motorized feedwater control valve in order to regulate the flowrate accordingly.

The level controller is of the proportional type and provided with a manual control facility. In addition it features a signal for high-level alarm, first low-level alarm and a current output for the display unit URA used for remote level indication.

The switchpoints are adjustable within the whole measuring range of the level electrode.

Level control NRG 26-21 / NR. 2-1

This water-level controller is to be used in conjunction with one level electrode NRG 26-... and one limit switch NRS 2-1.

A second max.-min. limit switch enables establishing additional switchpoints such as high level alarm and first low-level alarm.

Using level transmitter NRT 2-1 and display unit URA makes remote level indication possible.

The advantage of this switching controller lies in customized switchpoints which can be adjusted during operation and the simultaneous use of several control units.

Level control LD 144 / KS 92-1

Used in conjunction with μ P controller type KS 92-1 for modulating water level control (pressure range > PN 40).

The intelligent buoyancy transmitter works on the Archimedean buoyancy principle. The buoyancy is proportional to the liquid level and transformed by the measuring transducer into the standard output signal 4...20 mA.

Level control 705 / KS 92-1

Used in conjunction with μ P controller type KS 92-1 for modulating water level control (pressure range > PN 40).

Can also be used as combination electrode together with limiters. The 705 is a radar-based level transducer. The reflexion time is a function of the level and will be transformed into a 4...20 mA standard output signal by the measuring transducer.

Modulating control with adjustable switchpoints

Pressure rating PN 40

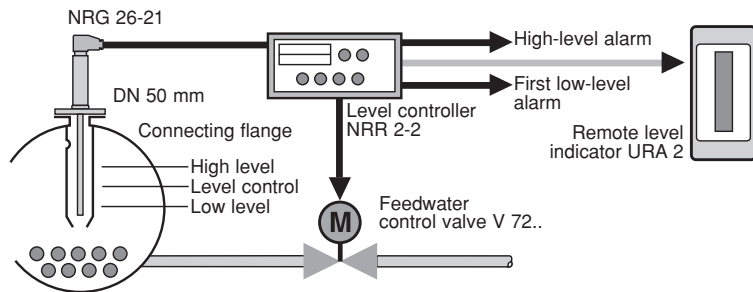

Equipment		Stock code
NRG 26-21	H = 1000 mm	345 21 47
NRR 2-2e	230 V	324 13 43
URA 2	230 V	331 13 44

Type approval
TÜV · WR · 01-320

Control valve with isolating bypass valve, strainer, non-return valve and feedback potentiometer

Pressure rating PN 40

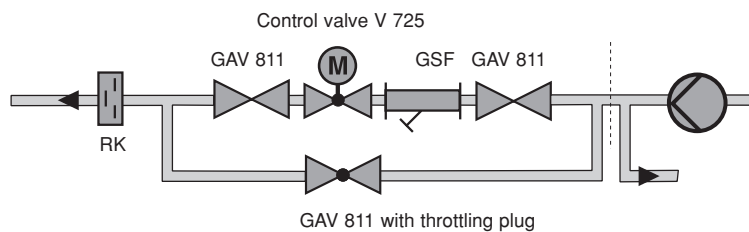

Equipment	Boiler capacity t/h	DN
3 x GAV 811, Control valve V725, GSF, RK	< 2.5	20
	< 8.0	40
	< 16.0	50
	< 28.0	65

For other nominal sizes refer to pages

GAV	73
GSF	71 – 72
RK	30 – 37
V 725	61

On-off control with adjustable switchpoints

Pressure rating PN 6

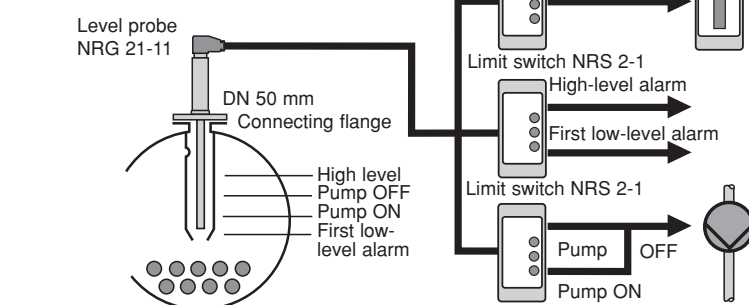

Equipment	Stock code	Qty
NRG 21-11	H = 1000 mm	342 12 47
NRS 2-1	230 V	323 17 41
NRT 2-1	230 V	330 14 41
URA 2	230 V	331 13 44

Optional voltages for NRS 2-., URA.
Special voltage: 115 V, 24 V, 50..60 Hz

High-Pressure Level Control / Pump Control

Continuous level monitoring for high-pressure applications

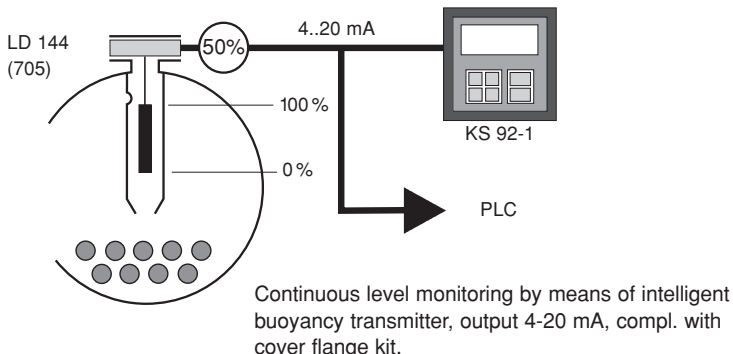

Type	PN	Design	Measuring range
LD 144 24 V, DC	100	DN 80	350
		DIN 3526	500
		Form E	1000
705 24 V, DC	100	DN 80	350
		DIN 2696	500
		Form L	1000
	160	DN 50	600
		DIN	800
		Form E	1000

Description

Level pot for external installation of level electrodes

Stop Valve GAV

Purpose

For isolating and throttling non-corrosive and aggressive gases, steam and liquids, e. g. air, steam, gas, oil etc. in all industries.

Features

- Maintenance-free
- Safety stuffing box
- Detachable locking device for all sizes
- Rising stem design
- Position indicator (detachable)
- Optional limit switch(es)
- Outside screw
- Rolled spindle thread
- Asbestos-free

Y-type drain valve 17/213

Additional equipment for the installation of liquid-level alarms

SRL-63

Purpose

In combination with external low-level alarms for monitoring the periodic purging of level pots or, generally, as timer for monitoring any periodic function.

Particularly suitable for steam plant operation to TRD 602/604.

Design

All-electronic logic unit **SRL-63** for continuous monitoring, with three LEDs (stand-by, purging, switching off) with case for mounting on walls.

Operation

The monitoring equipment with Mini-PLC periodically activates a memory for a defined period of time. During this period the memory registers all functional operations, e. g. purging of the level pot. If this signal is not received within the fixed period, the plant is shut down. The plant is also shut down if the purging process lasts for more than five minutes.

Type code of level pots

Feature	Value	Designation	MF 206-1STT 118P/214P/312G >
Component	Level pot	MF	↑
Design: (side connection)	1 Side connection	10	↑
	2 Side connection	20	↑
	4 Side connection 90°r	40	↑
	4 Side connection 90°l	41	↑
	4 Side connection 180°	42	↑
	4 Side connection 90°r+90°l	60	↑
Nominal pressure	PN 16	4	↑
	PN 40	6	↑
	PN 63	7	↑
	PN 160	9	↑
Size	88.9	1	↑
	114.3	2	↑
Material	Steel type ST 35.8	S	↑
	High-temperature steel 15 MO 3	W	↑
	Austenitic	A	↑
In accordance with	AD-Bulletin	A	↑
	TRD	T	↑
	Others	S	↑
Approved by	TÜV	T	↑
	Works inspector	W	↑
	Others	S	↑
Connection (N 1)	3/4" BSP	114 G	↑
	1" BSP	115 G	↑
	1 1/4" BSP	116 G	↑
	1 1/2" BSP	117 G	↑
	DN 50 mm	118 P	↑
	DN 80 mm	120 P	↑
	DN 100 mm	121 P	↑
Boiler connection (N 2)	DN 15 mm	212 P	↑
	DN 20 mm	214 P	↑
	DN 25 mm	215 P	↑
	DN 50 mm	218 P	↑
Drain connection (N 3)	1/2" BSP	312 G	↑
	DN 20 mm	314 P	↑
	DN 25 mm	315 P	↑
Side connection 3 + 4 (N 4)	DN 20 mm	414 P	→ not required in this example
	DN 25 mm	415 P	→ not required in this example
Side connection 5 + 6 (N 5)	DN 20 mm	514 P	↑
	DN 25 mm	515 P	↑
Centre distance	1500	ME 1500	↑
Length (top)	e. g. 230	Spec. >	↑
Length (bottom)	e. g. 170	Spec. >	↑
Volume	11 l	Spec. >	↑
Serial no.	12345 to 123460	Spec. >	↑

Additional specification

Centre distance ME = 1500 mm
 Length (top) = 230 (not < 190 mm)
 Length (bottom) = 170 (not < 140 mm)
 Volume = 11 l
 Serial no. = 12345 to 123460

Accessories for liquid-level alarms fitted in external level control pots

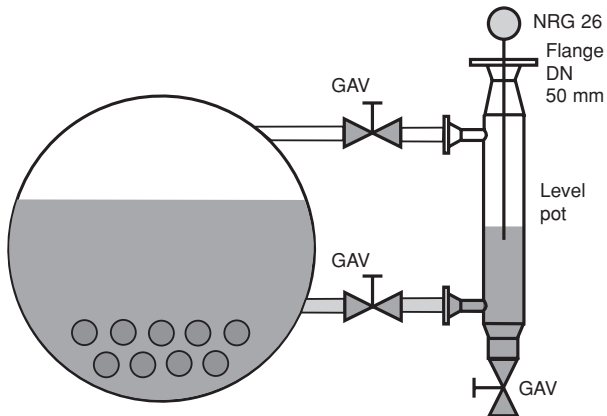

Type	DN/PN	Pressure/Temp. Ratings		Qty.
		P _{max}	t _{max}	
MF 2061 STT ¹⁾ GAV 811, DN 20 mm 17/213, 1/2" BSP	40	32 bar	238 °C	2
MF 2071 STT ²⁾ GAV 130, DN 25 mm	63	60 bar	275 °C	3
MF 2091 STT ²⁾ GAV 136, DN 25 mm	160	75 bar	290 °C	3
MF 2091 WTT ²⁾ GAV 136, DN 25 mm	160	100 bar 96 bar	311 °C 300 °C	3

¹⁾ Approval acc. to PED 97/23/EC, module A1

²⁾ Approval acc. to PED 97/23/EC

Accessories for level controls fitted in an external level control pot

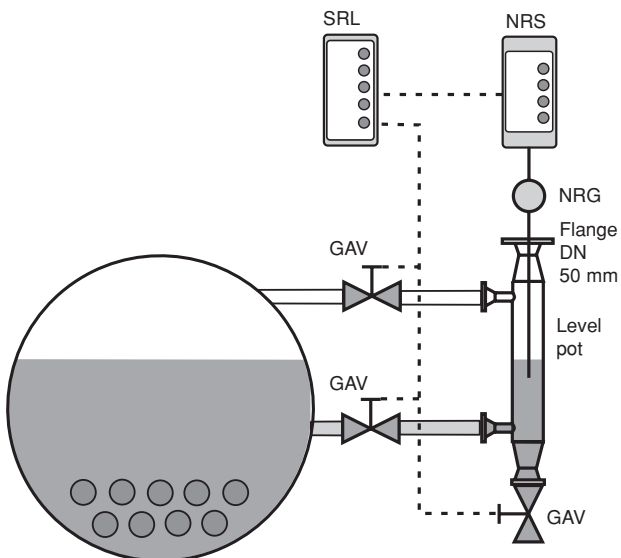

Type	DN/PN	Pressure/Temp. Ratings		Qty.
		P _{max}	t _{max}	
MF 2061 STT ¹⁾ GAV 811-II GAV 811-I SRL 63	20/40	32	238 °C	2
MF 2071 STT ²⁾ GAV 130-II GAV 130-I SRL 63	25/63	60	275 °C	2
MF 2091 STT ²⁾ GAV 136-II GAV 136-I SRL 63	25/160	75	290 °C	2
MF 2091 WTT ²⁾ GAV 136-II GAV 136-I SRL 63	25/160	100 96 96	311 °C 300 °C 300 °C	2

¹⁾ Approval acc. to PED 97/23/EC, module A1

²⁾ Approval acc. to PED 97/23/EC

Combination electrodes with self-monitoring level limiter

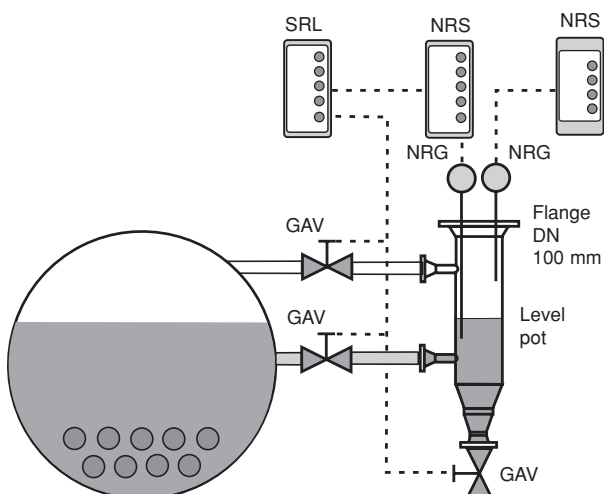

Type	DN/PN	Pressure/Temp. Ratings		Qty.
		P _{max}	t _{max}	
MF 2062 STT ¹⁾ GAV 811-II GAV 811-I SRL 63	20/40	32	238 °C	2
MF 2072 STT ²⁾ GAV 130-II GAV 130-I SRL 63	25/63	60	275 °C	2
MF 2092 STT ²⁾ GAV 136-II GAV 136-I SRL 63	25/160	75	290 °C	2
MF 2092 WTT ²⁾ GAV 136-II GAV 136-I SRL 63	25/160	100 96 96	311 °C 300 °C 300 °C	2

¹⁾ Approval acc. to PED 97/23/EC, module A1

²⁾ Approval acc. to PED 97/23/EC

Optional extra: SRL

Optional voltage 115 V, 24 V, 50..60 Hz

Design

The probe works without any moving parts. The probe rod, which is insulated by a ceramic tube, is inserted through a hole in the probe flange such that pressure-tight sealing is ensured. The ceramic tube is closed at the lower end and covered by a protection tube.

The electronic control unit is housed in the terminal box. The wiring is effected via a 6 pole connector with crimp connection.

Operation

The principle of capacitance measurement is used to sense liquid levels. The probe rod and the protection tube form a capacitor, with air or the particular liquid being the dielectric. In electrically conductive liquids the probe insulation serves as dielectric. As the level rises or falls, the capacitance of this assembly changes, is converted in the integral measuring transducer into a signal, and is then fed to the associated electronic control unit.

NRG 211

In combination with level switch NRS 2-4 for indicating high-water level and level switch NRS 2-5 for indicating low-water level at very high pressures and temperatures (up to PN 320, 550 °C).

Application in draining systems of conventional power stations and high-pressure steam boilers.

NRS 2-4

The level switch NRS 2-4 is an analogue electronic amplifier for the capacitance electrode type NRG 211.

In combination with this level electrode the unit can detect high water level. In addition, the level switch evaluates possible malfunction signals coming from the electrode and monitors the electrode supply cable and can therefore be used as part of a controlled draining system in power stations.

NRS 2-5

The level switch NRS 2-5 is an analogue electronic amplifier for the capacitance electrode NRG 211.

In combination with this level electrode the unit can detect low water level. In addition, the level switch evaluates possible malfunction signals coming from the electrode and monitors the electrode supply cable and can therefore be used as part of a minimum level monitoring system/low-level system.

URN 2

The power supply unit type URN 2 in combination with up to four level switches and the cycling timer can be used as part of a controlled drainage system in power stations or for low level indication.

Example of installation

Use the PSU type URN 2 only for the power supply of a maximum of four level switches type NRS 2-4 or NRS 2-5 and the cycling timer type PRS 9.

PRS 9

The PRS 9 is an analogue/digital cycling timer. In combination with up to four level switches type NRS 2-4 and a position-controlled limit switch the cycling timer can be used as part of a controlled draining system in a power station.

Example of installation

Use cycling timer PRS 9 only in combination with GESTRA level switches NRS 2-4.

Description

Steam boiler equipment for marine applications has to comply with the same requirements as those placed on land installations.

In addition to that further demands regarding environmental conditions such as climate, vibrations etc. have to be met.

The acceptance certificates are to be issued by the classification society responsible for the ship's acceptance inspection.

Approvals for marine application see page 86

Self-monitoring low-level limiter

Level electrode NRG 16-11 S DN 50 mm

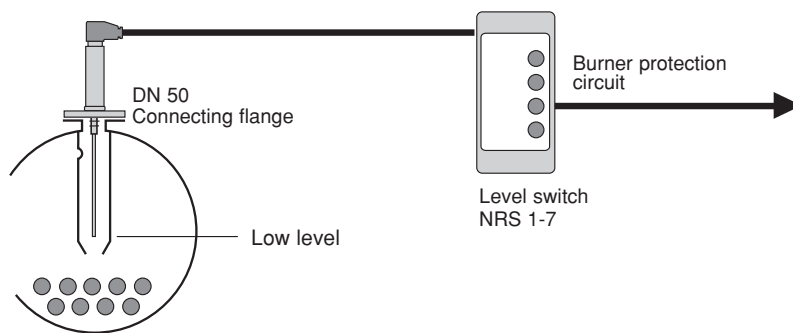

Type	PN	Stock code
NRG 16-11 S 1000 mm	40	3511442
NRS 1-7 230 V, 15 s		323254153

Self-monitoring low-level limiter and continuous level control

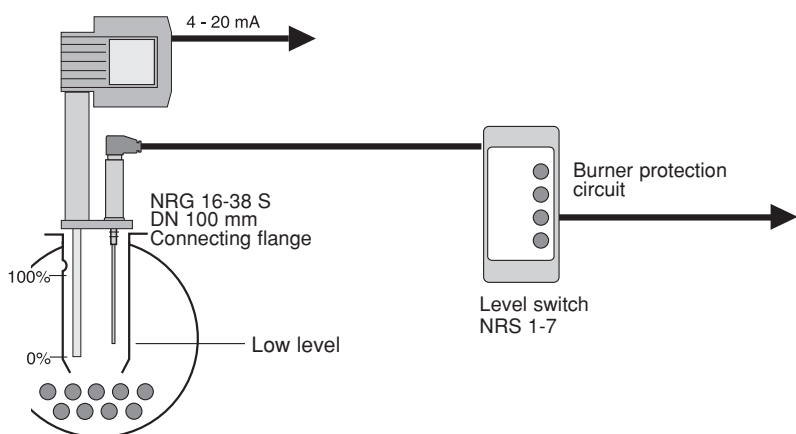

Type	PN	max. length supplied	Stock code
NRG 16-38 S	40	779	3582044
		884	3582045
		989	3582046
		1095	3582047
		1513	3582051
NRS 1-7 230 V, 15s			323254153

Self-monitoring limiter and modulating level control

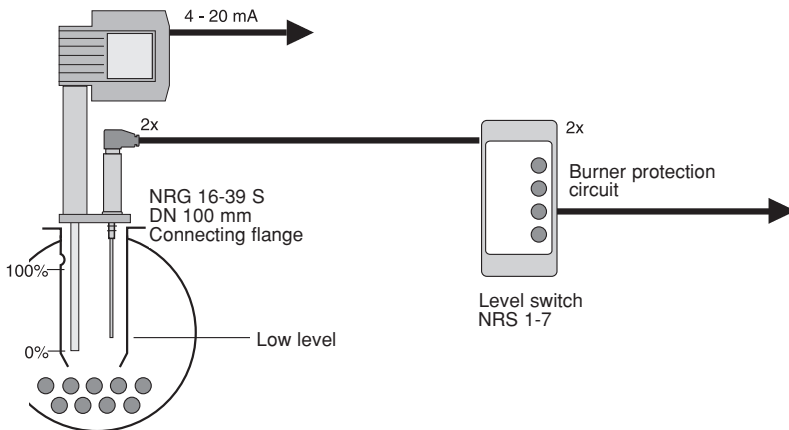

Type	PN	Max. length supplied	Stock code
NRG 16-39 S	40	779	3584044
		884	3584045
		989	3584046
		1199	3584047
		1513	3584051
NRS 1-7 2x 230 V, 15s			323254153

Compact system for modulating level control

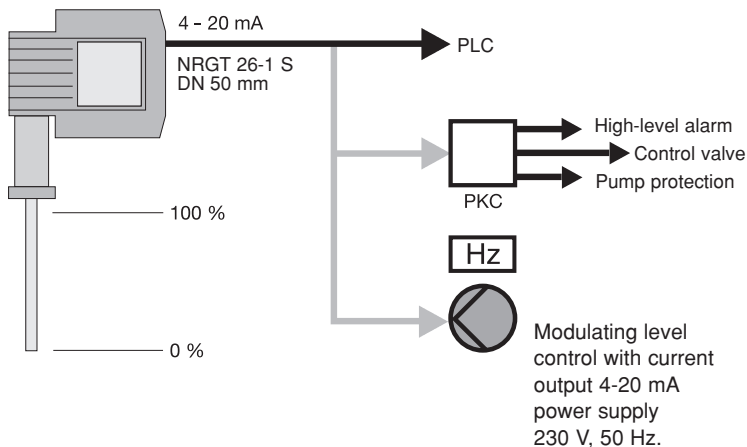

Type	PN	Max. length supplied	Stock code
NRGT 26-1S	40	316	3211452
		420	3211453
		526	3211454
		631	321455
		737	3211456
		842	3211457
		947	3211458
		1053	3211459
		1579	3211460

Optional 115 V, 50..60 Hz

Compact system for on-off level control with fixed switchpoints

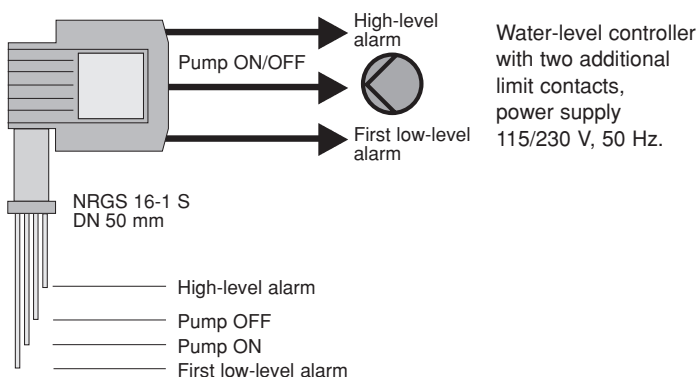

Type	PN	Max. length supplied	Stock code
NRGS 16-1S	40	938	3534053
		1438	3534056



**GESTRA,
pioneers in
boiler
controls.**

As one of the leading manufacturers of steam traps, valves and SMART boiler control systems, GESTRA has played a prominent role in the implementation of intelligent boilerhouse automation. Our experience, gained in thousands of applications, ensures the user of receiving products of the highest quality and reliability and is based on the following three principal rules:

- ▶ Always offer complete solutions and customer related support services.
- ▶ Ensure the highest quality and utmost reliability of all component parts.
- ▶ Provide advanced automation systems to guarantee perfect fluid control.

GESTRA products have many practical uses where steam is generated and distributed, fluids flow, energy saving is desired and environmental protection and safety oriented control systems are needed.

To maintain our standards of excellence on site and to consider the individual requirements of each customer, GESTRA has created a sales organisation which is divided into five branches. Our highly trained teams of sales engineers are capable of coming up with customized solutions to tough problems in the following key sectors of the fluid control industry:

1. For industrial customers, shipyards and power stations
2. For distributors
3. For intelligent automation systems and boiler manufacturers
4. For industrial systems engineering and process control
5. For international clients

Authorized representatives in strategic locations in over 70 countries ensure that the world is supplied with GESTRA products. Providing total capability throughout every stage of steam and process fluid handling, GESTRA can truly make a difference in plant performance, efficiency and safety . . . and that's guaranteed.